

---

# Weighing Indicator

## User manual

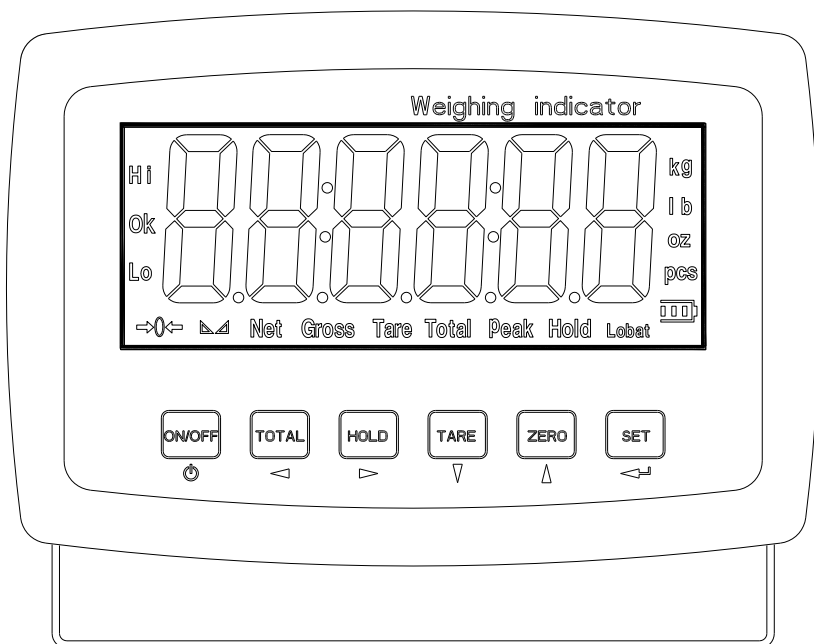



**Safety instruction**

For safety operation, pls. follow the safety instruction.



**WARNING**

Set, calibrate, inspect and fix the weighing indicator is prohibited by Non professional staff.



**WARNING**

Pls. make sure the weighing display well earthing.



**WARNING**

The indicator is electrostatic sensitive device, pls. power off during electrical connections, internal components touched by hand is prohibited, and please take the anti-static measure.

## LIST

1. Summary .....	3
1.1 Main function .....	3
1.2 Technical parameter .....	3
1.3 Outline and installation picture .....	4
1.4 Battery .....	4
2. Installation and Calibration .....	5
2.1 Connection indicator with load cell.....	5
2.2 Communication interface .....	5
3. Basic operation.....	6
3.1 Key and display.....	6
3.2 Power on.....	8
3.3 Zero setting.....	9
3.4 TARE.....	9
3.5 HOLD.....	9
3.6 TOTAL .....	10
3.7 Ten times high resolutions.....	11
3.8 Up and Low limit alarm .....	11
3.9 Print function.....	11
4 Calibration & parameter setting .....	12
4.1 Enter calibration .....	12
4.2 Step of calibration operation: .....	12
4.3 Application parameter setting.....	14
4.4 Communication setting .....	15
4.5 Application setting .....	16
4.6 Exit setting .....	18
5. Output data format .....	18
5.1 Computer continuous sending format .....	18
5.2 Big display continuous sending format .....	19
5.3 Serial interface reception command: .....	20
5.4 Print output format .....	20
5.5 Print the accumulated output format .....	21
6. Maintenance .....	21
6.1 Regular error and maintain method.....	21
6.2 Daily maintenance.....	22
6.3 Restore default parameters .....	22

# 1. Summary

## 1.1 Main function

- » General weighing: zero tare
- » Animal weighing: Peak-hold. Data-hold, Auto-hold
- » Accumulation
- » Optional by RS232
- » Low battery alarm
- » Power off automatically

## 1.2 Technical parameter

- » Excitation voltage: +3.3 VDC
- » A/D converting speed: 10 SPS
- » Load signal range: 0~12.8mV
- » Load capacity: it can connect 4 pcs 350Ω load cell at most
- » Weight unit: kg
- » Resolution: 3000e
- » Interval: 1/2/5/10/20/50
- » Display: 6-digits LED/LCD, digital height: 50mm
- » Key: ON/OFF TOTAL HOLD TARE ZERO SET
- » Interface: RS232C Baud rate optional 1200/2400/4800/9600
- » Operation temperature: -10°C ~ +40°C
- » Storage temperature: -20°C ~ +60°C
- » Optional power: 4V/4Ah rechargeable battery  
110/220VAC

## 1.3 Outline and installation picture

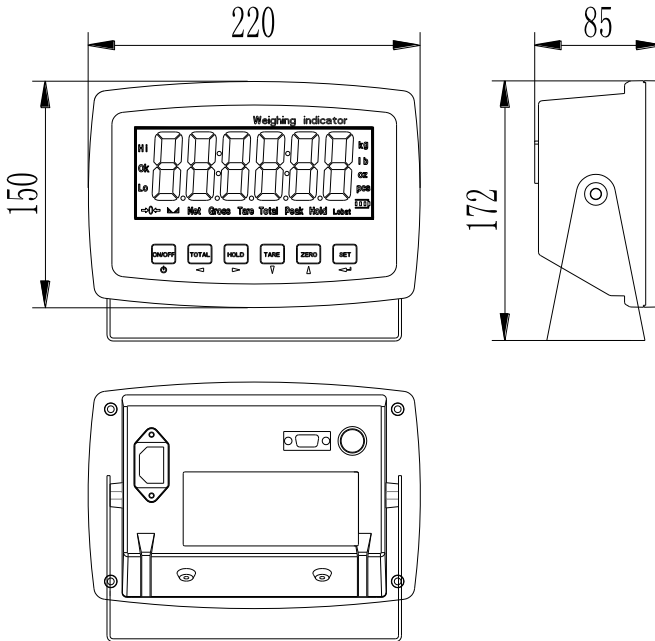

## 1.4 Battery

1. When you use the internal battery first time. You should charge the battery 10-12 hours to prevent low voltage resulted from self leakage of battery.
2. The battery voltage could be checked from the light on the right bottom of the display. When low-voltage, "battery symbol" flickering and LOBAT shining on LCD display; Red light flickering on LED display, then please recharge the battery.
3. Charge time: 10-12 hours. And it works 40 hours.

4. When the battery light turns green on LED display or “battery marking” all full on LCD display , it means charging finish.
5. If you don’t use the indicator for a long time, please take out the battery to protect the indicator from the battery leakage.

## 2. Installation and Calibration

### 2.1 Connection indicator with load cell

It can connect four pcs 350Ω load cell at most, both four and six line load cell are ok. To make it simple, we use quick connector or standard plug.

As below:

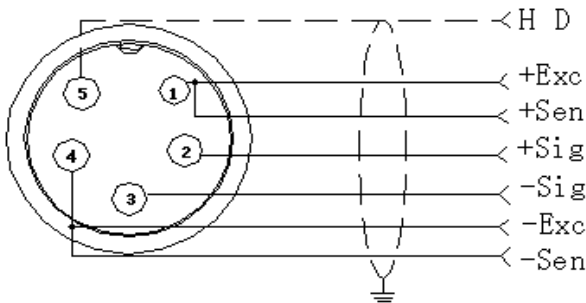

Quick connector connection

### 2.2 Communication interface

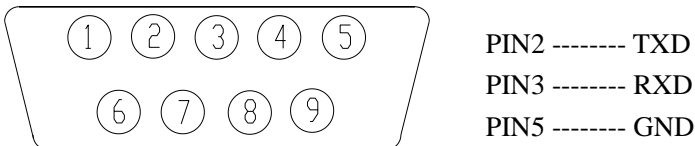

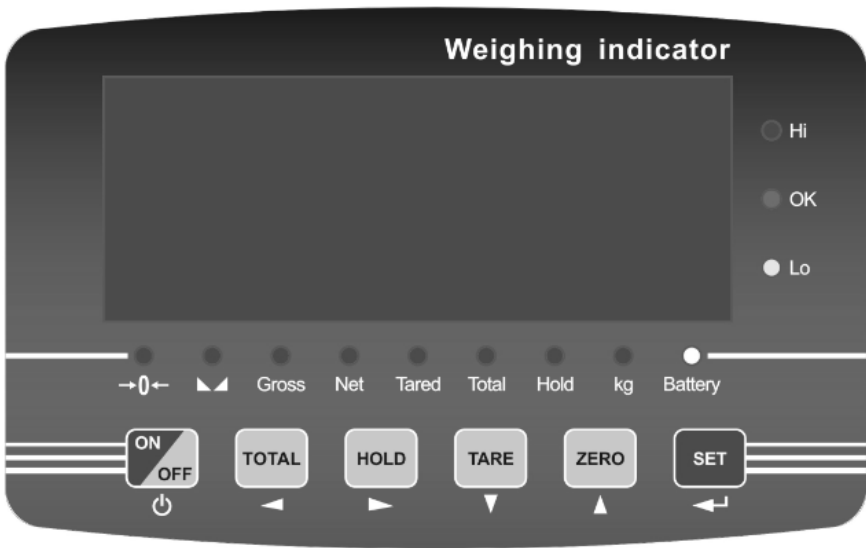

# 3. Basic operation

## 3.1 Key and display

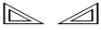

Weighing indicator display instruction

LED display	Instruction
	Weighing data display
Kg	Weight unit kg
HOLD	Hold the data

Tare	Display tare status
Net	Display net weight
Gross	Display gross weight
	Display data keep still
	Zero, indicating zero weight
Battery	Using battery
Hi	Over Limit
OK	Within Limit
Lo	Below Limit
Total	Accumulation
Count	Counting function

Key's function



ON/OFF, Exit and save setting



Left



Right



Down









Up



Confirm, Go to next step



Key symbol	Key name	Key function
	SET	Work together with “on/off” enter and exit calibration
	ZERO	Clear weight within zero range
	TARE	1.At Gross mode, tare the loaded weight 2.At Net mode, display gross weight after deduct tare
	HOLD	Enter and exit “hold” mold
	TOTAL	Accumulating operation
	ON/OFF	Press it for 2 seconds to power on or power off

## 3.2 Power on

Power on and indicator perform self-checking and go to weighing mode.

## 3.3 Zero setting

Within zero range, press “zero”, indicator weighing is cleared. When Indicator is not stable, zero is unworkable.

## 3.4 TARE

At the gross weight mode, if the weight is stable, pls. press “Tare” key, the indicator will take the loaded weight as tare, and show net weight.

At this time the gross mode will change to net mode. The “net” and “tare” light is on, and the net weight is zero.

## 3.5 HOLD

C11=0 “hold” function unworkable

C11=1 PEAK HOLD

Press “HOLD” key, the Hold light is on, and show the maximum data on the weighing indicator. Press “HOLD” key again to exit the hold function.

C11=2 Data-hold

Press “HOLD” key, the Hold light is on, and show the data on the weighing indicator. Press “HOLD” key again to exit the hold function.

C11=3 Auto-hold

If the weight on the scales above 20d and keep stable, the indicator will show the data for 6 seconds and the “ hold” light is on , after 6 seconds the indicator back to general weighing, and the “ hold” light is off.

C11=4 Special Animal weighing function

Press “Hold” key, the indicator will show “LOC” for 3 seconds, the “hold” light is on. During the 3 seconds, the indicator will catch the average weight and show it.

Press “HOLD” key again to exit it.

## 3.6 TOTAL

Accumulation operation

At Zero mode, load weight till stable, Press “TOTAL” key go to accumulating mode, “total” light on, display” n001”, and then display loaded weight; unload weight , back to zero, load weight again till stable. Press “TOTAL”, display“n002”, then show the loaded weight. Repeat it maximum 999 times.

Check the total weight operation:



Press “SET” hold it then press “TOTAL”, at the same time, display “n\*\*\*”, (accumulating times) then display total weight.

There are 8 data totally. It shows the first 4 digital, then the last 4 digital.

For example, the first 4 digital is“0012”, the last 4 digital is“34,56”

It means the actual weight is “1234.56”.

At TOTAL (accumulate) mode, Press “TOTAL” key the indicator show “clr n”, it means don’t clear the total Weight, Press  key to confirm it and exit ;

if clear total weight, Press  or  “clr n” change to “clr y”, it means clear total weight display. Press  to clear the the total weight and exit accumulating mode.

## 3.7 Ten times high resolutions

Press “ SET” and “TARE” key at the same time, you will get 10 times high resolutions. And it back to normal weighing after 3 seconds.

## 3.8 Up and Low limit alarm

Pls. set C13= Up limit, C14=Low Limit, when the weight is over up limit, the “HI” light will be on, and indicator will make a sound to alarm.; when the weight is below than the low limit, the “LO” light will be on.. when the weight is within the limit, the “OK” light is on.



## 3.9 Print function



When the data is stable, connect with printer, it will be printed after press  1 second.

## 4 Calibration & parameter setting

### 4.1 Enter calibration

There are two methods to enter the setting menu:

1. When the switch “CAL” is off, Press  then press  at the same time, hold it, you will enter C08-C39 setting.

2. Take out the sealing screw on the back of indicator, then press down the “span” Press  still and then press  at the same time , you will enter C01-C39 setting.

### 4.2 Step of calibration operation:

According to the second method which can enter setting menu, C01-C39

C01 UNIT

[C01    ] Press 

[C1    1] unit is kg

Press , go to next step

C02 Set decimal digits

[C02 ] Press 

option: 0/1/2/3/4

- [C2 0] no decimal point
- [C2 1] one decimal point
- [C2 2] two decimal point
- [C2 3] three decimal point

Press , go to next step

### C03 Division setting

[C03 ] Press 

- [C3 1] d=1
- [C3 2] d=2
- [C3 5] d=5
- [C3 10] d=10
- [C3 20] d=20
- [C3 50] d=50

Press , go to next step

### C04 Maximum capacity

For example: max weighing 100kg:

set [0100.00]



Press , go to next step

### C05 Zero calibration

option: 0=non-calibration zero      1=need calibration zero

calibration zero please choose 1 and ensure scale is empty and “stable” light is on. countdown[CAL 10]~[CAL 0], then the indicator will show[0.00](example for two decimal point).

### C06 Loading calibration

[C06], Press , show [C6 0], press , change to [C6 1], Press , show [SPAn ],

Basic on max capacity setting, add suitable weight on scale. close to the max capacity, heavier than 10% max at least.

For example: the weight is 80kg

As bellows:

[0080.00]

[CAL 9]

.....

[0080.00]

[CALEnd]

count down over, indicator shows loaded weight , loading calibration finish.

If you want to set application parameter. Press  If you want to exit.

Press 

### C07 Default parameters setting

[C7 0] non-restore default parameters

[C7 1] restore default parameters

Note: after the above parameters setting finish, please do not set default parameters often, avoid the original setting parameters lost.

## 4.3 Application parameter setting

### C08 warning tone

[C8 1] Open warning tone

[C8 0] Close warning tone

### C09 Power off automatically

- [C9 0] Non-power off
- [C9 10] Keep still within 10 min. power off automatically
- [C9 30] Keep still within 30 min. power off automatically
- [C9 60] Keep still within 60 min. power off automatically

C10 Power saving setting

- [C10 0] Close backlight
- [C10 1] Close backlight after 1 minute
- [C10 2] Always backlight

C11 Hold

- [C11 0] No Hold function
- [C11 1] Peck hold
- [C11 2] Data hold
- [C11 3] Auto-hold
- [C11 4] Animal weighing

C12 Hold time ( if you choose C11=4, you can set the time )

- [C12 3] 3 seconds
- [C12 5] 5 seconds

C13 Upper limit alarm value

C14 Low limit alarm value

C15 Check inner code

## 4.4 Communication setting

C18 Serial interface setting

- [C18 0] No sending
- [C18 1] Big display
- [C18 2] Print format output
- [C18 3] Command mode(Z =zero T=tare R=Reply weight
- [C18 4] continuous sending

C19 BAUD RATE

- [C19 0] 1200bit/s



[C19 1]	2400bit/s
[C19 2]	4800bit/s
[C19 3]	9600bit/s

## 4.5 Application setting

### C20 Manually Zero

[C20 00]	No Manually Zero
[C20 01]	Manually Zero range $\pm 1\%$ Max. capacity
[C20 02]	Manually Zero range $\pm 2\%$ Max. capacity
[C20 04]	Manually Zero range $\pm 4\%$ Max. capacity
[C20 10]	Manually Zero range $\pm 10\%$ Max. capacity
[C20 20]	Manually Zero range $\pm 20\%$ Max. capacity
[C20100]	Manually Zero range $\pm 100\%$ Max. capacity

### C21 Initially zero

[C21 0]	No initially zero
[C21 1]	Initially zero range $\pm 1\%$ Max. capacity
[C21 2]	Initially zero range $\pm 2\%$ Max. capacity
[C21 5]	Initially zero range $\pm 5\%$ Max. capacity
[C21 10]	Initially zero range $\pm 10\%$ Max. capacity
[C21 20]	Initially zero range $\pm 20\%$ Max. capacity

### C22 Zero tracking range

[C22 0.0]	No zero tracking
[C22 0.5]	$\pm 0.5d$
[C22 1.0]	$\pm 1.0d$
[C22 2.0]	$\pm 2.0d$
[C22 3.0]	$\pm 3.0d$
[C22 4.0]	$\pm 4.0d$
[C22 5.0]	$\pm 5.0d$

### C23 Zero tracking time

[C23 0]	No zero tracking
---------	------------------

[C23 1] 1 second

[C23 2] 2 seconds

[C23 3] 3 seconds

#### C24 Overload range

[C24 09] Over 9d than max. capacity

#### C25 Negative display

[C25 00] Less than -9d

[C25 10] Less -10% Max. capacity

[C25 20] Less -20% Max. capacity

[C25 50] Less -50% Max. capacity

[C25100] Less -100% Max. capacity

#### C26 Standstill time

[C26 0] Quick

[C26 1] Medium

[C26 2] Slow

#### C27 Standstill range

[C27 1]  $\pm 1d$

[C27 2]  $\pm 2d$

[C27 5]  $\pm 5d$

[C27 10]  $\pm 10d$

#### C28 Dynamic filter

[C28 0] Close dynamic filter

[C28 1] Low dynamic filter

[C28 3] Medium dynamic filter

[C28 5] High dynamic filter

#### C29 Noisy filter

[C29 0] Close noisy filter

[C29 1] Low noisy filter

[C29 2] Medium filter

[C29 3] High filter



## 5.2 Big display continuous sending format

Output continuous format																	
S	S	S	S	X	X	X	X	X	X	X	X	X	X	X	X	C	C
T	W	W	W												R	K	
X	A	B	C												S	S	
1	2			3						4						5	6

State A			
Bits0,1,2			
0	1	2	Decimal point position
1	0	0	XXXXXXXX0
0	1	0	XXXXXXXXX
1	1	0	XXXXX. X
0	0	1	XXXX. XX
1	0	1	XXX. XXX
Bits3,4			Division
0		1	X1
1		0	X2

State B	
BitsS	function
Bits0	gross=0, net=1
Bits1	symbol: positive =0, negative =1
Bits2	overload (or lower zero) =1
Bits3	dynamic=1
Bits4	unit: lb=0, kg=1
Bits5	Constant 1
Bits6	Constant 0

State C			
Bit2	Bit1	Bit0	unit
0	0	0	Kg or lb
0	0	1	g
0	1	0	t
Bit 3			printing=1
Bit 4			Extend display=1
Bit 5			Constant 1
Bit 6			Constant 0

## 5.3 Serial interface reception command

RS232COM serial interface can receive simple ASCII command.

Command word and role as follows:

Command	name	role
T	Tare off command	Save and clear tare
Z	Zero command	Zero the gross weight
P	Print command	Print the weight
R	Read gross/ net weight	Read gross/net weight

## 5.4 Print output format

```
NET      XX.X kg
TARE     XX.X kg
GROSS    XXX.X kg
```

## 5.5 Print the accumulated output format

Total: 003 (accumulate times, example for 3 times is 003)

Total: 2.88kg (accumulate weight)

## 6. Maintenance

### 6.1 Regular Error and maintain method

Error	Reason instruction	Solution
Display UUUUUU	<ol style="list-style-type: none"> <li>1.the loaded weight excess overload range of max. capacity</li> <li>2.wrong connection with load cell or no connection with it.</li> <li>3. load cell unworkable</li> </ol>	<ol style="list-style-type: none"> <li>1.decrease loaded weight</li> <li>2.check load cell connection.</li> <li>3.checking load cell: check input and output resistance to judge it is good or not.</li> </ol>
Display nnnnnn	<ol style="list-style-type: none"> <li>1. calibration is no good</li> <li>2.cell single line is connect a wrong line.</li> <li>3.the cell is bad.</li> </ol>	<ol style="list-style-type: none"> <li>1.check scale is resisted or not, foot is kept level or not.</li> <li>2.check load cell connection.</li> <li>3.checking load cell: check input and output resistance to judge it is good or not.</li> </ol>
ERR1	during calibration, no input added weight or input weight exceed max capacity.	input the correct weight

ERR2	during calibration, the added weights not enough	added weight at least 10% of Max.capacity, Recommend the weights is 60-80% the Max. capacity
ERR3	during calibration, input single is negative.	1.check connection is correct or not. check load cell is damaged or not. 3. renew calibration, if still wrong. pls replace the PCB
ERR4	during calibration, single is unstable	ensure added weight and scale is stable, start calibration
ERR5	EEPROM check error	change PCB.

## 6.2 Daily maintenance

1. In order to ensure indicator display clearly and prolong use life, the indicator should not be placed directly on sunlight.
2. Load cell and indicator should be well connected , the system should have a good ground, away from strong electric field, magnetic field.
3. Do not use indicator outside in rainy, to keep it power off is better.
4. Power off firstly while plug and unplug.

## 6.3 Restore default parameters

Enter setting menu, set C07= 1,press  then press  exit saving

setting, all parameters will be back to default setting.

Note: Pls. do not restore default parameter easily if you are not professional and have not scale calibration.

Default parameter form

Parameter	Instruction	Default value
C01	Calibration unit	1
C02	Decimal digits	0
C03	Division value	1
C04	Max capacity	10000
C05	Empty scales calibration	0
C06	Capacity calibration	0
C07	Restore the default parameters	0
C08	Warning tone	1
C09	Automatic power off	0
C10	Power saving mode	0
C11	Hold function	0
C12	Animal weighing mode	0
C13	Upper limit warning	000000
C14	Lower limit warning	000000
C15	Inner code display	
C16	Date	
C17	Time	
C18	Serial interface data output method	0
C19	Serial interface Baud rate	3=9600
C20	Manual zero setting	2
C21	Initial zero setting	10
C22	Automatic zero tracking range	0.5
C23	Automatic zero tracking time	1



C24	Verload range	9
C25	Negative display range	10
C26	Standstill time	1
C27	Standstill range	2
C28	Dynamic filter	0
C29	Noisy filter	2
C30~C40	Reseverd menu	